

Assembly Instructions



Table of Contents:

Parts List	2
Assembly Instructions	3
Warranty Information	4



PARTS LIST

ITEM	DESCRIPTION	QTY.	PART NO.
	Hardware Pack consists of A-H below:	1	85981
A	Square neck carriage bolt - 5/16"-18 x 1" long	4	80144
B	Hex lock nut - 5/16"-18	4	80676
C	Hex head bolt - 7/16"-14 x 3-3/4" long	2	80045
D	Lock nut - 7/16"-14	2	80605
E	Flat washer - 7/16"	4	80713
F	Washer - 5/8" x 3/32" (thick)	4	80705
G	Washer - 5/8" x 1/32" (thin)	2	80707
H	Cotter pin for axle 1/8" x 1"	2	81077
I	Handle assembly	1	3027220
J	Aluminum nose	1	302782
K	Wheel	2	varies
Optional Items			
L	Load containment arm (Figure 2)	1	302725
O	Hex lock nut - 5/16"-18	for load containment arm option	80676
M	Button head screw - 5/16"-18 x 1" long	for load containment arm option	80177

- TOOLS REQUIRED**
- (2) 1/2" COMBINATION WRENCH
 - (1) 5/8" COMBINATION WRENCH
 - (1) 7/16" COMBINATION WRENCH
 - (1) #3 PHILLIPS SCREW DRIVER (NEEDED ONLY FOR OPTIONAL CONTAINMENT ARM INSTALLATION)
 - (1) 11/16" SOCKET AND RATCHET
 - (1) PAIR NEEDLE NOSE PLIERS

FIGURE 1

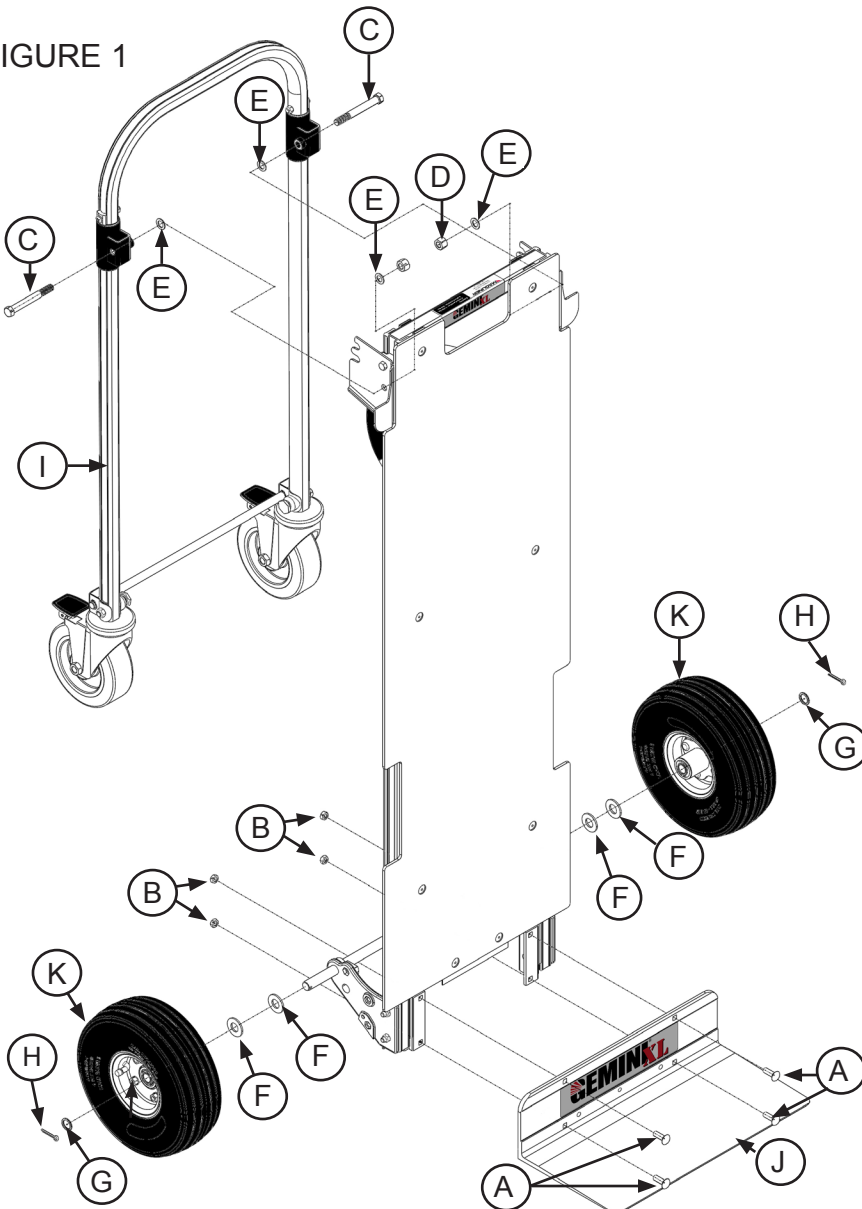

STEP 1: ASSEMBLE THE NOSE AND WHEELS TO THE FRAME

Nose Assembly

Note: For easier assembly it may be necessary to lay the truck horizontally to attach the nose.

1. Position the nose (J) on the mounting brackets so the square holes align with each other.
2. Insert one (1) square neck carriage bolt (A) through the nose plate (J) in each of the four (4) holes. Finger-tighten the four (4) hex lock nuts (B) on the carriage bolts (A) at this time. **Do not fully tighten hex lock nuts until all four carriage bolts are in place.**
3. Secure each of the four (4) carriage bolts (A) with four (4) hex lock nuts (B) and tighten securely (torque value of 120-140 in-lbs.).
4. Fully tighten the two (2) lock nuts on the two (2) bolts found on BOTH the right hand and left hand wheel brackets affixed to the frame (torque value of 120-140 in-lbs.).

Wheel Assembly

1. Slide two (2) thick washers (F) on the axle.
2. Slide wheel (K) onto the axle with the long hub portion facing in.
3. Slide one (1) thin washer (G) on the axle.
4. Insert one (1) cotter pin (H) through hole on the end of the axle, as shown in Figure 1. Bend the ends of each cotter pin using the needle nose pliers to hold in place.
5. Repeat steps 1 through 4 for other wheel.

STEP 2: ASSEMBLE THE HANDLE

1. Position the handle assembly (I) so holes in the pivot sockets align with holes in the pivot plate with one (1) handle washer (E) between each of them. Note: washers must be placed in correct location to ensure proper handle fit.
2. Insert one (1) hex head bolt (C) through the pivot socket and pivot plate.
3. Slide one (1) flat washer (E) on the hex head bolts and thread on one (1) lock nut (D) by hand.
4. Repeat steps 1 through 3 for other pivot socket.
5. Using socket, tighten bolt to remove all free play, then loosen 1/2 turn. Adjust bolts as necessary to allow handle to slide freely.

STEP 3: ASSEMBLE THE LOAD CONTAINMENT ARM (OPTIONAL ITEM)

1. Insert both pan head machine screws (M) through the load containment arm brackets and the extruded nose hole, as shown in Figure 2, and tighten the hex lock nuts (O) securely (torque value of 120-140 in-lbs.).
2. If required, tighten the other nuts on the load containment arm brackets until the load containment arm can be repositioned and remain in its repositioned location. Do not over tighten.

Load Containment Arm Option

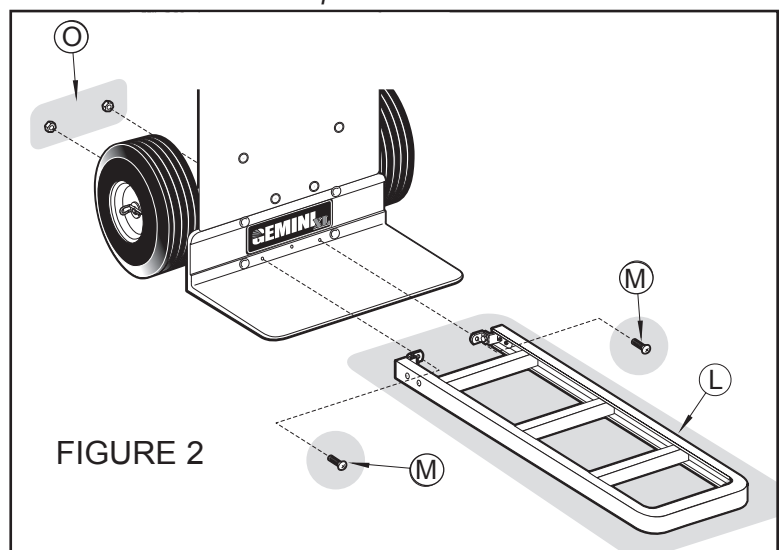

MAGLINE, INC.
1205 W. Cedar Street • Standish, MI 48658 USA
1-800-MAGLINE (624-5463) • (989) 512-1000 (outside U.S. & Canada)
www.magliner.com