

Assembly Instructions

Paddle Brake Y-Cable

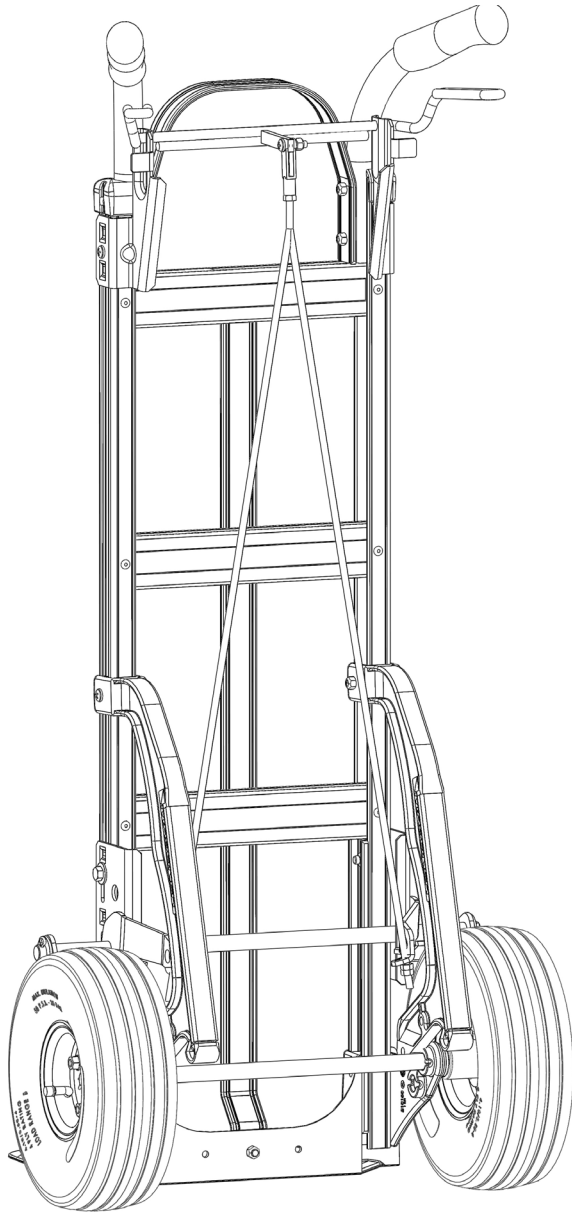

Table of Contents:

Bottom Brake Components	2-3
Brake Handle Components	4-7
Y-Cable Assembly	7
Brake/Cable Adjustments	8
Warranty Information	8

MAGLINER®

www.magliner.com

Magline, Inc., 1205 West Cedar Street, Standish, MI 48658 • (800) 624-5463, (989) 512-1000

BOTTOM BRAKE COMPONENTS

PARTS LIST

Item	Description	Qty.	Part No.
A	Bottom mounting bracket	2	304152
B	Hex head cap screw - 5/16"-18 x 1-1/2" long	2	80013
C	Flat washer for 5/16" bolt	2	80701
D	Hex locknut - 5/16"-18	2	80676
E	Pivot shaft	1	304157
F	Flat washer for 5/8" bolt - thick	4	80705
G	Brake paddle LH	1	304155
H	Brake paddle RH	1	304156
I	Cotter pin for axle 1/8" x 1" long	2	81077

TOOLS REQUIRED

(2) 1/2" WRENCHES
(2) 7/16" WRENCHES
(1) #2 PHILLIPS SCREWDRIVER
(1) NEEDLE NOSE PLIERS
(1) RULER OR TAPE MEASURE

ADDITIONAL TOOLS REQUIRED IF RETROFIT TO EXISTING TRUCK:

(1) ELECTRIC DRILL
(1) 3/8" DRILL BIT

The above parts are found in 304160, 304161, 304162 and 304163 brake conversion kits.

Tighten all 1/4"-20 screws to 50-60 in.-lbs. and 5/16"-18 screws to 120-140 in.-lbs.

For retrofitting Y-cable brake kit to an existing hand truck see directions at bottom of this page.

1. The bottom mounting brackets require a hole that lines up with the top hole in the side rail reinforcement (located on the inside of the bottommost part of all hand truck frames). For hand trucks that already have holes in the side rails for mounting the bottom mounting brackets, use a screwdriver to punch a hole through the red stripe.
2. Position each of the bottom mounting brackets (A) as illustrated in Figure 2. Fasten with the 5/16" x 1 1/2" long hex head cap screw (B) and one 5/16" washer (C) on the outside through the uppermost slot. Secure with the 5/16" locknut (D) on the inside. (Note: Do not fully tighten until the final brake adjustment is done.)
3. Slide the pivot shaft (E) through each of the lower holes provided in the mounting brackets and install a 5/8" washer (F) on each end.
4. Assemble each of the brake paddles (G,H) on the pivot shaft as illustrated, making sure that each of the extending lower tabs (TAB) are positioned towards the center of the hand truck as shown.
5. Install a second 5/8" washer (F) on each end of the pivot shaft and secure the assembly by inserting a cotter pin (I) in the holes provided at both ends of the shaft. Bend the ends of each of the cotter pins (I) using the needle nose pliers to hold it in place.

FIELD RETROFIT

When retrofitting a Y-cable brake kit to an existing hand truck without the side rail hole that lines up with the top hole in side rail reinforcement, mounting holes will need to be drilled in the frame, one on each side.

1. Using a ruler or tape measure, mark a location in the center of the side rail 7 3/4" above the wheel bracket as illustrated in Figure 3 on both sides.
2. Drill a hole using a 3/8" drill bit in the location marked.

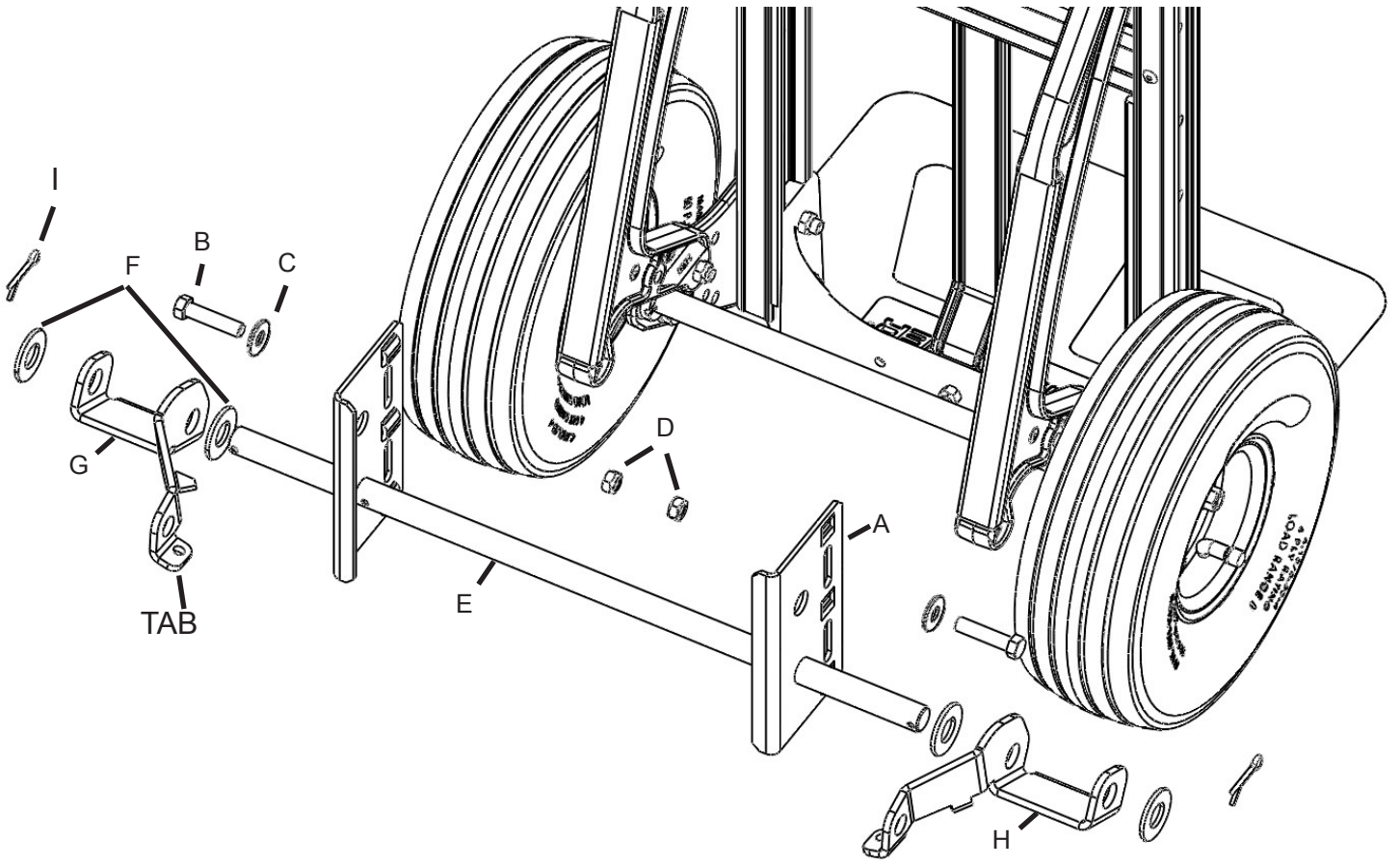

Figure 1

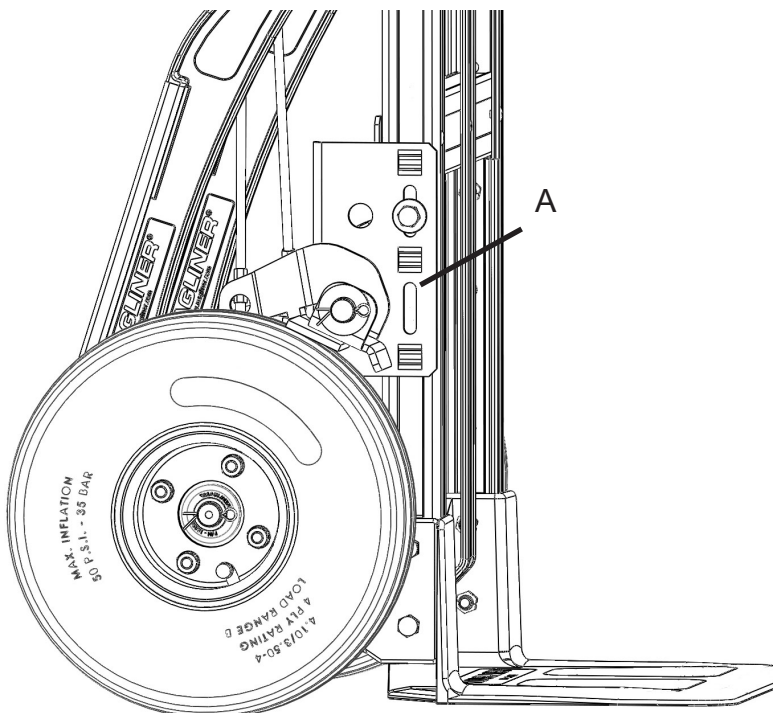

Figure 2

Drill a 3/8" diameter hole if it does not exist. See FIELD RETROFIT instructions.

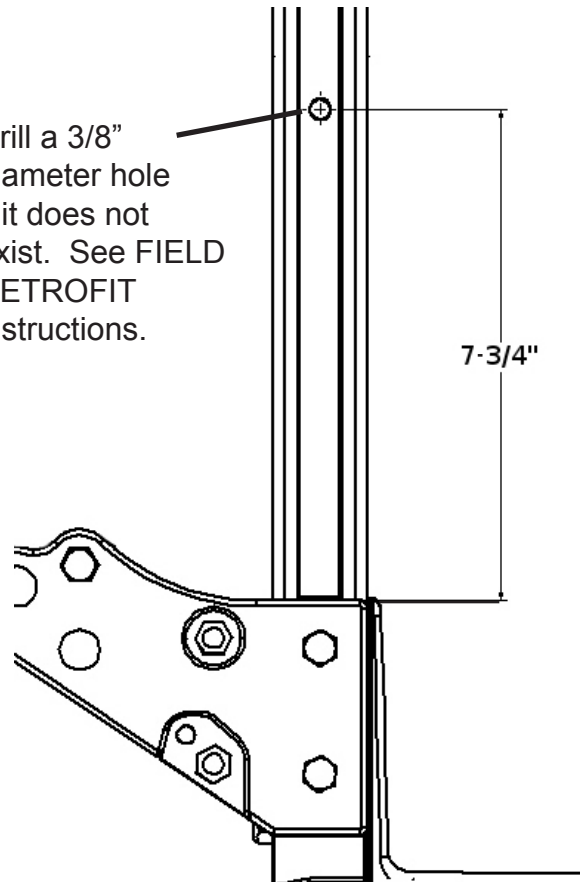

Figure 3

DOUBLE GRIP HANDLE PADDLE BRAKE ACTUATOR ASSEMBLY (NO. 16 HANDLE)

Item	Description	Qty.	Part No.
A	Pan head machine screw - 1/4"-20 x 2-1/4" long	2	80263
B	Hex locknut - 1/4"-20	2	80675
C	Handle mounting bracket LH	1	304153
D	Handle mounting bracket RH	1	304154
E	Double grip brake handle actuator	1	304151
F	Flat washer for 3/8" bolt	2	80702
G	Cotter pin - 3/32" x 3/4"	2	81075

Parts A-G provided in double grip handle brake conversion kit 304161.

1. Remove the lower existing pan head machine screw and locknut on each side of the hand truck handle using the #2 Phillips head screwdriver and the 7/16" wrench.
2. Position the LH handle mounting bracket (C) as illustrated in Figure 4 with the tab (TAB) facing away from center of the truck and secure it with a 1/4" x 2 1/4" long pan head machine screw (A) and 1/4"-20 locknut (B).
3. Slide a 3/8" washer (F) on the LH end of the handle actuator (E) and insert actuator through the hole in the LH handle mounting bracket (C) and hold in place. Slide a 3/8" washer (F) on the RH end of the handle actuator then slide the RH handle mounting bracket (D) over the end and slide bracket into place.
4. With the brake actuator handle in place resting on the tabs, assemble the RH handle mounting bracket to the side rail using a 1/4" x 2 1/4" long pan head machine screw (A) and 1/4"-20 locknut (B). Securely tighten the mounting bracket using the #2 Phillips head screwdriver and the 7/16" wrench.
5. Install a cotter pin (G) on the inside of each 3/8" washer (F) in the holes provided. Using the needle nose pliers bend the end of the cotter pins to keep secure.

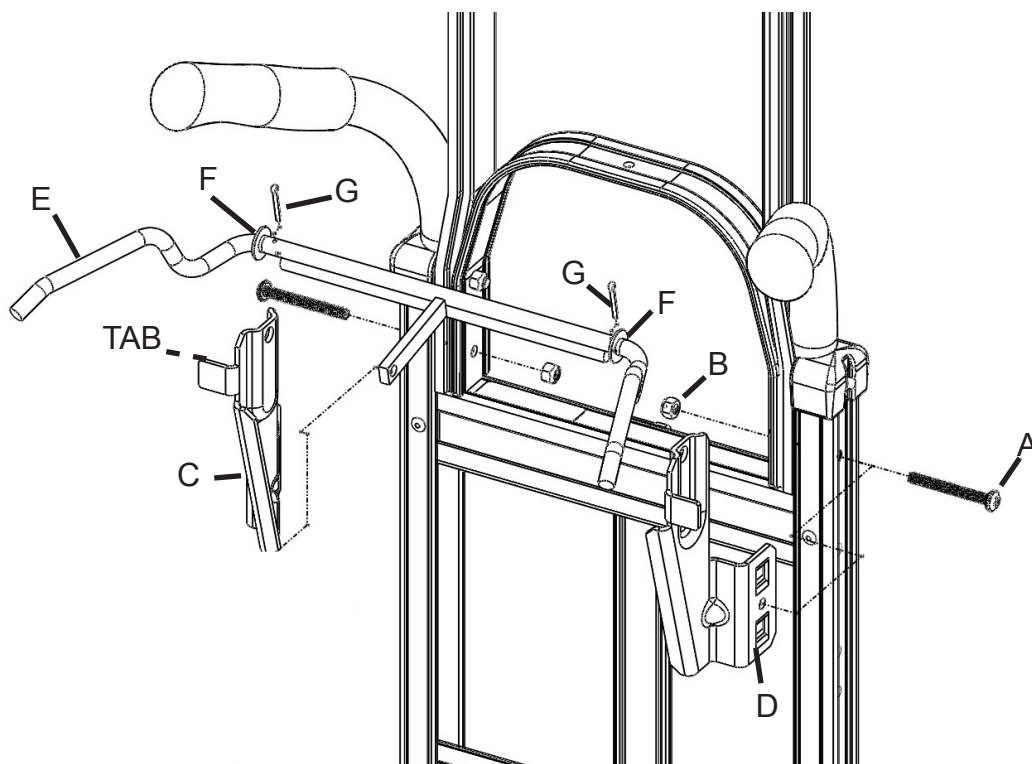

Figure 4

LOOP TYPE HANDLE PADDLE BRAKE ASSEMBLY (NO. 11, 12, 19, 22 HANDLES)

Item	Description	Qty.	Part No.
A	Pan head machine screw - 1/4"-20 x 2-1/4" long	2	80263
B	Hex locknut - 1/4"-20	2	80675
C	Handle mounting bracket LH	1	304153
D	Handle mounting bracket RH	1	304154
E	Loop handle actuator	1	304150
F	Flat washer for 3/8" bolt	2	80702
G	Cotter pin - 3/32" x 3/4"	2	81075

Parts A-G provided in loop handle brake conversion kit 304160.

1. Remove the lower existing pan head machine screw and locknut on each side of the hand truck handle using the #2 Phillips head screwdriver and the 7/16" wrench.
2. Position the LH handle mounting bracket (C) as illustrated with the tab (TAB) facing away from center of the truck and secure it with a 1/4" x 2 1/4" long pan head machine screw (A) and locknut 1/4"-20 (B) as illustrated in Figure 5.
3. Slide the loop handle actuator (E) through the hole in the mounted LH handle mounting bracket and the RH handle mounting bracket (D). With the actuator handle resting on the tabs of the mounting brackets, assemble the RH mount to the side rail using a 1/4" x 2 1/4" long pan head machine screw (A) and locknut 1/4"-20 (B) as shown. Securely tighten the mounting screws using the #2 Phillips head screwdriver and the 7/16" wrench.
4. Slide a 3/8" washer (F) on each end of the loop handle actuator and install a cotter pin (G) in the holes provided. Using the needle nose pliers bend the end of the cotter pins to keep secure.

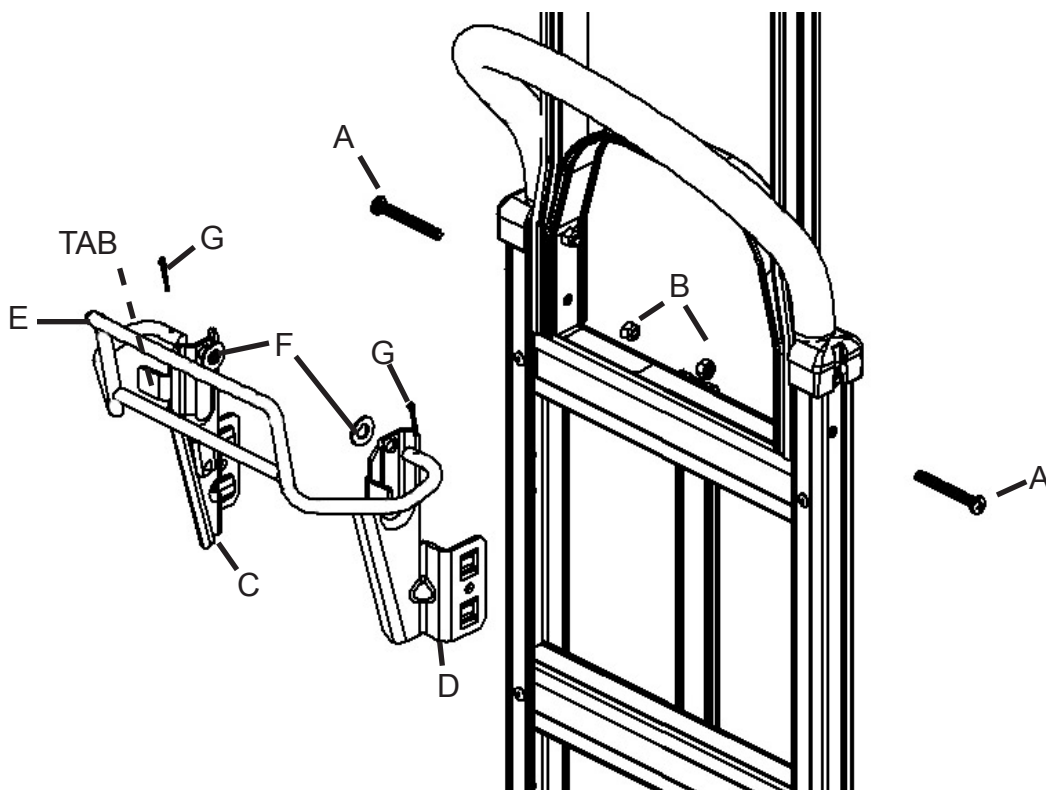

Figure 5

SINGLE PIN HANDLE PADDLE BRAKE ACTUATOR ASSEMBLY (NO. 13A-C, 15A-C AND 17 HANDLES)

Note: If your hand truck model uses any of the handles listed above, you must purchase a brake handle version of that handle if the handle does not have the welded slotted stub (see part labeled STUB below).

Handle Description (handle sold separately)	Part No.
Handle No. 13A straight loop with cross brace and single pin with brake - 52"	300986
Handle No. 13B straight loop with cross brace and single pin with brake - 55"	301003
Handle No. 13C straight loop with cross brace and single pin with brake - 60"	300987
Handle No. 15A vertical loop with brake for straight braced frames - 52"	300988
Handle No. 15C vertical loop with brake for straight braced frames - 52"	300979
Handle No. 17 straight loop handle with pistol grip for brake	301169

Item	Description	Qty.	Part No.
A	Spacer - 1/4" ID x 5/16" long	1	304058
B	Brake lever assembly	1	304065
C	Pan head machine screw - 1/4"-20 x 1-1/4" long	1	80104
D	Hex locknut - 1/4"-20	1	80675
E	Stub collar for 13, 15 and 17 handles	1	304137

Parts A-E provided in single pin handle brake conversion kits 304162 and 304163.

1. Remove all four existing pan head machine screws and locknuts on each side of the hand truck handle using the #2 Phillips head screwdriver and the 7/16" wrench.
2. Pull out the old handle and replace with the new handle with the welded slotted stub. Secure the new handle with the previously removed handle mount screws and locknuts. Firmly tighten the screws with the #2 Phillips head screwdriver and the 7/16" wrench.
3. Insert the steel bushing (A) in the largest endmost hole in the brake lever assembly (B) and position the assembly in the slot of the handle stub. Hold the handle in place while sliding the stub collar (E) in place over the end of the stub.
4. Insert the 1/4"-20 x 1-1/4" long pan head machine screw (C) through the stub and lever assembly and secure with the 1/4"-20 locknut (D) using the #2 Phillips head screwdriver and the 7/16" wrench.

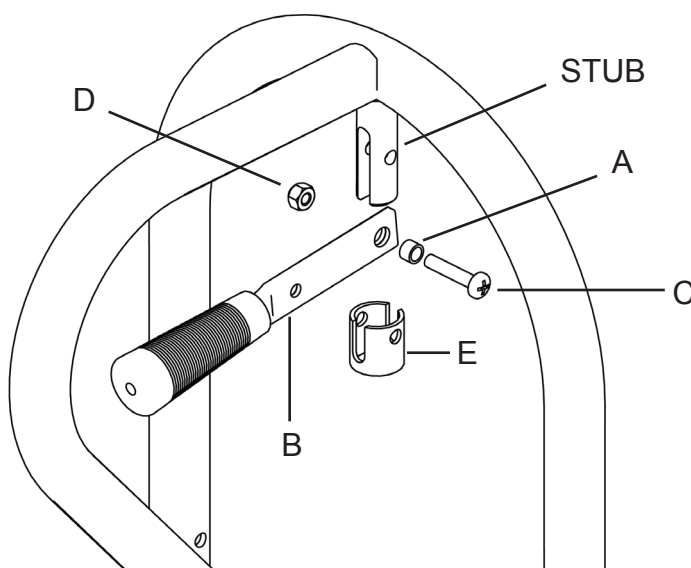

HANDLE RETROFIT PARTS INSTALLATION (NO. 13A-C, 15A-C AND 17 HANDLES)

Note: If your hand truck model is currently a Magliner paddle brake truck with any of the brake handles listed above and the handle was purchased before February 2015, you may NOT need to install a stub collar. If this is the case please use the instructions below to install the brake lever assembly.

Item	Description	Qty.	Part No.
A	Spacer - 1/4" ID x 5/16" long	1	304058
B	Brake lever assembly	1	304065
C	Pan head machine screw - 1/4"-20 x 1-1/4" long	1	80104
D	Hex locknut - 1/4"-20	1	80675

1. Insert the steel bushing (A) in the largest endmost hole in the brake lever assembly (B) and position the assembly in the slot of the handle stub (see Figure 6).
2. Insert the 1/4"-20 x 1-1/4" long pan head machine screw (C) through the stub and lever assembly and secure with the 1/4"-20 locknut (D) using the #2 Phillips head screwdriver and the 7/16" wrench.

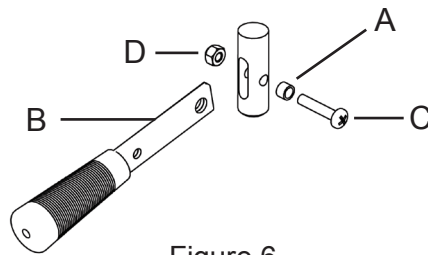

Figure 6

Y-CABLE ASSEMBLY

Item	Description	Qty.	Part No.
-	Y-cable 27" (used with 11, 12, 19, 22, 13A-C and 16 handles)		304139
-	Y-cable 34" (used with 15A-C and 17 handles)		304149
A	1/4"-28 jam nut	5	80665
B	Yoke end	1	304056
C	Pan head machine screw - 1/4"-20 x 1" long	1	80102
D	Hex locknut - 1/4"-20	1	80675
E	Brake adjustment spacer (shown on next page)	2	304073

1. Insert each of the lower ends of the Y-cable in the holes located on the extending lever tabs (TAB) of each brake paddle as illustrated in Figure 7.
2. Thread one 1/4"-28 jam nut (A) onto both ends of the cable to approximately 1-1/2" from the end using your fingers. (Note: It may be necessary to use a 7/16" wrench and hold the cable with a pair of pliers above the threaded section to prevent the cable from spinning while performing this step.)
3. Thread a second 1/4"-28 jam nut (A) onto the cable until it is snug with first jam nut and tighten them together using the two 7/16" wrenches to 50-60 in.-lbs. of torque.
4. At the top of the cable, thread one 1/4"-28 jam nut (A) all the way on the upper end of the Y-cable. Thread the yoke end (B) onto the cable as illustrated in Figure 8. You will adjust the final position of the yoke and jam nut on the next page.

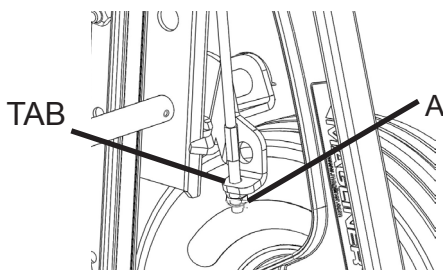

Figure 7

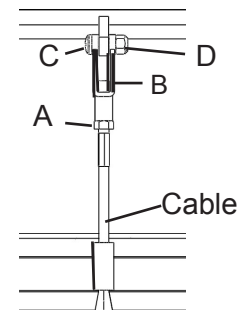
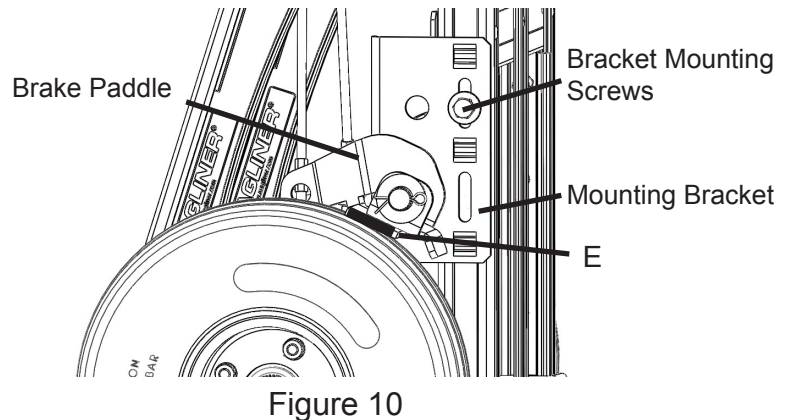
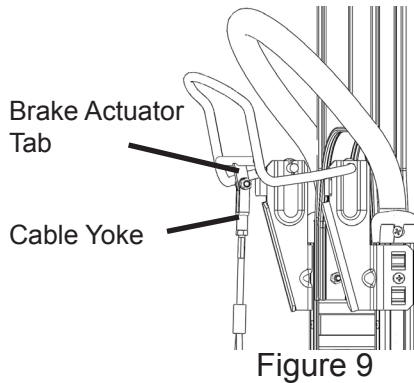

Figure 8

PADDLE ADJUSTMENT (REQUIRED DURING THE INITIAL INSTALLATION OR IF WHEELS ARE CHANGED FROM ONE TYPE TO ANOTHER)

1. Loosen the jam nut (A) below the yoke end (B) at the top of the Y-cable using a 7/16" wrench (see Figure 8).
2. Remove the yoke from the brake handle actuator tab using a #2 Phillips head screwdriver and a 7/16" wrench.
3. Loosen the hex head screws that hold the bottom mounting brackets on each side of the frame using two 1/2" wrenches. Slide the brackets down such that the brake paddles are resting on the wheels (bottom mounting brackets are shown on page 3, Figure 2).
4. Place an adjustment spacer (E) between each of the wheels and their respective brake paddles as illustrated in Figure 10.
5. With the brake assembly resting on each of the adjustment spacers, tighten each of the two bottom mounting bracket screws to secure the brackets in place using the 1/2" wrenches.
6. Remove the adjustment spacers.



ADJUSTING THE CABLE TENSION

1. While the yoke is unattached from the brake handle actuator, pull up on the cable until the paddles make contact with the wheels.
2. Turn the yoke on the top of the cable clockwise (moving down the cable's threaded stud) until the holes in the yoke are aligned with the holes in the brake handle actuator tab while pulling up on the cable (see page 7, Figure 9). Then loosen the yoke by turning it counter-clockwise several turns.
3. Attach the cable to the brake handle actuator tab with a 1/4"-20 x 1" long pan head machine screw (C) and 1/4"-20 locknut (D) and test to be sure there is no drag of the paddles on the wheels. If so, loosen the yoke another one or two turns and re-test. (Note: This typically requires the yoke to be loosened a total of 4 to 8 revolutions.)
4. When adjusted, tighten the screw and lock nut that secure the yoke to the actuator with the #2 Phillips head screwdriver and the 7/16" wrench.
5. Tighten the jam nut against the bottom of the yoke using the 7/16" wrench. Be sure the yoke can move freely on the actuator.

WARRANTY INFORMATION

Magline One-Year Limited Warranty

Magliner products have a one (1) year warranty from the date of purchase against defects in workmanship or material.

Any part or component, except items covered by warranties of other manufacturers, returned to the factory or service center freight prepaid by the owner, found upon examination by Magline, Inc. to be defective or the result of improper workmanship by the factory will be repaired or replaced without charge and returned to the owner freight prepaid by Magline, Inc.

Alterations of Magliner products void any warranty or liability on the part of Magline, Inc. Magline does not guarantee product capacity if alterations are made.

To submit warranty information, please visit our online warranty form in the "tools & resources" section of www.magliner.com